

**OWNERS MANUAL**  
**MODEL 150-SX**

**F.G. SERVO CONTROLLED, DIRECT DRIVE,  
AUTOMATIC SINGLE-PLAY TURNTABLE**

2. 45 RPM Adaptor

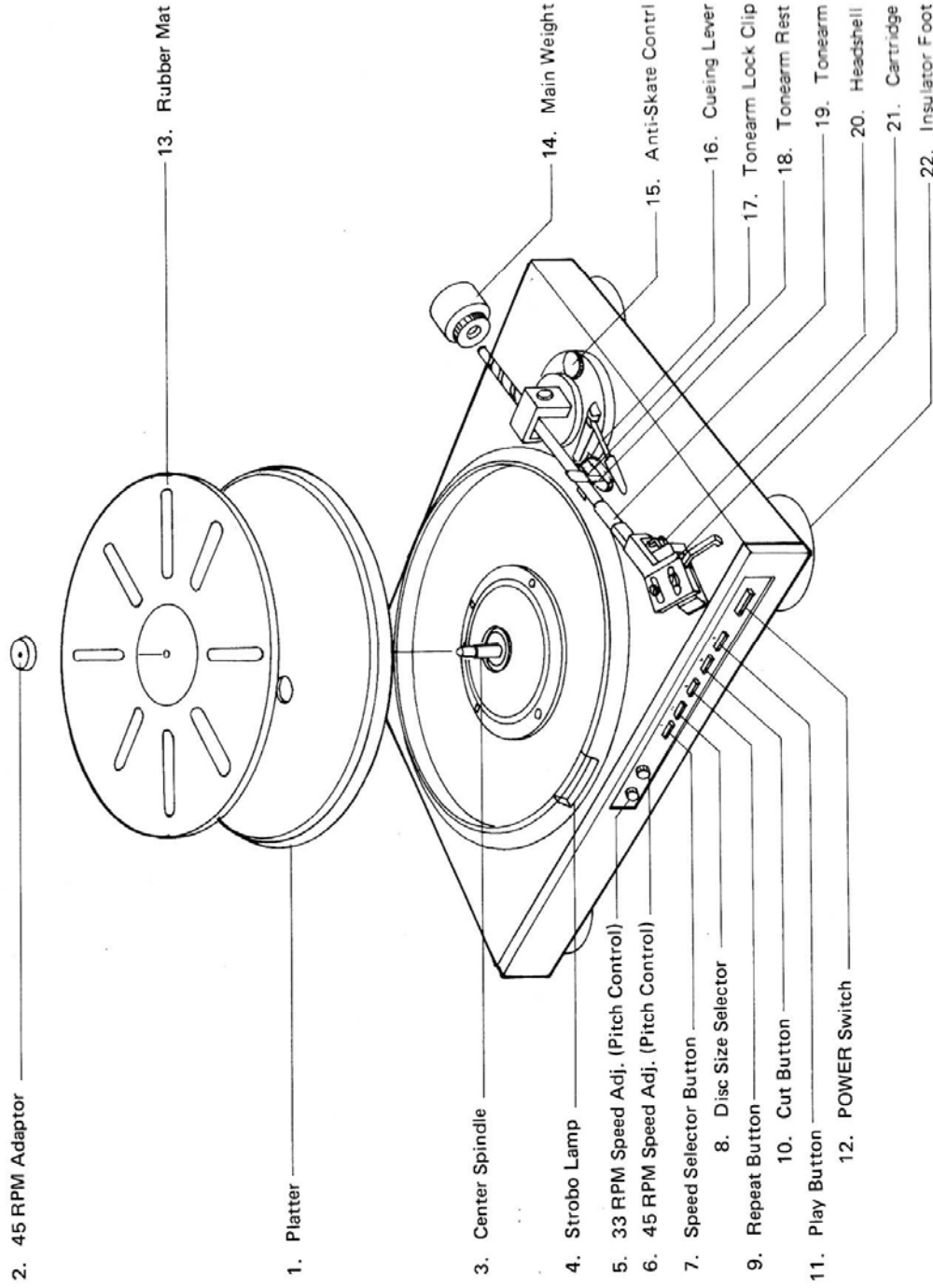

**WARNING: TO PREVENT POSSIBLE FIRE OR SHOCK HAZARD, DO NOT EXPOSE THIS TURNTABLE TO RAIN OR MOISTURE.**

**SPECIFICATIONS**

**TURNTABLE SPECIFICATIONS**      **NOMINAL VALUE**  
 Drive Motor . . . . . Coreless, slotless, brushless, 2-phase 8-pole magnet field type flat DC motor.  
 Speed Control & Drive System. . . . . FG Servo controlled direct drive.  
 Platter. . . . . 310 mm diameter aluminum die-cast weight: 1.4 kgs.  
 Wow & Flutter . . . . . 0.03% WRMS.  
 Signal to Noise Ratio . . . . . 67 dB (DIN-B).  
 Speed . . . . . 33-1/3 & 45 RPM 2-speed.  
 Speed Pitch Control Range . . . . . ±4%

**TONEARM SPECIFICATIONS**

Tonearm Type . . . . . Statically-balanced straight, low mass, tubular arm with direct reading tracking force adjustment, oil-damped cueing mechanism and anti-skating device.  
 Tonearm Effective Length. . . . . 227 mm pivot to stylus.  
 Tonearm Suspension System . . . . . pivot/bearing suspension.  
 Overhang. . . . . 16 mm.  
 Acceptable Cartridge Weight . . . . . 5-10 grms.  
 Tonearm Operation . . . . . Electronically controlled and operated by an independent DC motor.

**CARTRIDGE PERFORMANCE. . . . . NOMINAL VALUE**

Cartridge Type . . . . . ADC QLM34MK III-Induced Magnet Type.  
 Frequency Response . . . . . 20-25,000 Hz.  
 Channel Balance . . . . . Within 2 dB  
 Crosstalk between Channels. . . . . 25 dB at 1 kHz.  
 Output Voltage. . . . . 1.8 mV per CM/S  
 Optimum Load. . . . . 47 k ohms.  
 Tracking Force. . . . . 2.0±1.0 grms.  
 Stylus . . . . . 0.3 x 0.7 mil. elliptical diamond.

**OTHER SPECIFICATIONS**

Power Supply . . . . . 120 VAC 60 Hz.  
 Dimension  
 Cabinet . . . . . 450W x 42H x 353D (mm).  
 Overall . . . . . 450W x 125H x 353D (mm).  
 Weight. . . . . Approximately 7.2 kgs. (16 lbs)

**NOTE:** The above specifications are subject to change without notice for further improvement.

The BSR 150SX automatic turntable is precision engineered and manufactured to top quality standards to provide dependable operation and performance. It incorporates a low mass adjustable weight counter-balanced tonearm with low-mass plug-in headshell, lateral ball race bearings and anti-skate compensation. Viscous cueing controls the gentle lowering of the tonearm for optimum protection of the stylus and records. The diecast aluminum turntable platter is driven by an electronically controlled direct drive motor with a pitch control for speed adjustment, permitting adjustment over an 8% range and an illuminated stroboscope for accurate speed adjustment. A 'Cut' control terminates the playing of the record and returns the tonearm to the armrest. Low resonance material is used for the base construction and the base is supported by an isolated suspension system. Please read this manual before operating your unit to become familiar with its features and to assure your obtaining the performance that will bring you continued enjoyment for many years.

## **SAFETY INSTRUCTIONS**

1. **Read Instructions** — All the safety and operating instructions should be read before the appliance is operated.
2. **Retain Instructions** — The safety and operating instructions should be retained for future reference.
3. **Heed Warnings** — All warnings on the appliance and in the operating instructions should be adhered to.
4. **Follow Instructions** — All operating and use instructions should be followed.
5. **Water and Moisture** — The appliance should not be used near water — for example, near a bath tub, kitchen sink, laundry tub, in a wet basement or near a swimming pool, etc.
6. **Mount the appliance** either on a stable shelf or table.
7. **Ventilation** — The appliance should be situated so that it's location does not interfere with it's proper ventilation. For example, the appliance should not be situated on a bed, sofa, rug or similar surface that may block the ventilation openings; or, placed in a built-in installation, such as a book case or cabinet that may impede the flow of air through the ventilation openings.
8. **Heat** — The appliance should be situated away from heat sources such as radiators, heat registers, stoves or other appliances (including amplifiers) that produce heat.
9. **Power Sources** — The appliance should be connected to a power supply only of the type described in the operating instructions or as marked on the appliance.
10. **Grounding instructions or polarized connectors**, if described in the operating instructions must not be defeated.
11. **Power-Cord Protection** — Power cords should be routed so that they are not likely to be walked on or pinched by items placed upon or against them, paying particular attention to cords at plugs, convenience outlets and points where they exit from the appliance.
12. **Cleaning** — Clean the equipment with a dry dust cloth.
13. **Nonuse Periods** — The power cord of the appliance should be unplugged from the outlet when left unused for a long period of time.
14. **Object and Liquid Entry** — Care should be taken so that objects do not fall and liquids are not spilled into the enclosure through any openings.
15. **Damage Requiring Service** — The appliance should be serviced by qualified service personnel when:
  - A. The power supply cord or the plug has been damaged; or
  - B. Objects have fallen or liquid has been spilled into the appliance; or
  - C. The appliance has been exposed to rain; or
  - D. The appliance does not appear to operate normally or exhibits a marked change in performance; or
  - E. The appliance has been dropped or the enclosure damaged.
16. **Servicing** — The user should not attempt to service the appliance beyond that described in the operating instructions. All other servicing should be referred to qualified service personnel.

## UNPACKING

Your turntable has been carefully packed to prevent damage from shipping and handling. Carefully remove it from its carton and remove all foam packing, tape, tie-downs, etc. Make sure you have removed all accessory parts before making final disposition of the packing material. We recommend you save the carton and all packing materials, to afford your turntable maximum protection should you move or ship it in the future.

## ASSEMBLY

Turntable Assembly —

1. Carefully place the turntable on the motor shaft.
2. Place the rubber mat on the turntable.

## IMPORTANT:

Your turntable is supported by an isolated suspension system. Avoid sliding the unit when moving it from its position. Always lift the unit off the surface and lower it straight down to its desired location so that all four mounting feet rest squarely on the surface.

Avoid Hum Sources — Some amplifiers or other components can radiate hum fields which an adjacent turntable can pick up. Locate your turntable away from power transformers. Many times moving the turntable a few inches away is adequate.

## CARTRIDGE INSTALLATION/REPLACEMENT

The cartridge head is attached to the tonearm by aligning the flat portion of the cartridge head to the flat portion of the tonearm. Push the cartridge head into the tonearm and lightly tighten the lock screw in the cartridge head. When installing or removing the Cartridge Head Assembly always have the stylus guard installed to protect the stylus.

When you wish to replace the cartridge, proceed as follows:

- 1) Loosen the lock screw of the tonearm, and remove the headshell from the tonearm.
  - 2) Loosen the screws fastening the cartridge to the headshell, then remove the cartridge from the headshell.
  - 3) Remove the four lead wires of the headshell from the cartridge, taking care not to damage the wires.
  - 4) Connect the four lead wires to the new cartridge. The four lead wires are colour-coded as shown at the right, to help identify their polarities. Be sure to match the polarities correctly between the headshell and the new cartridge.
  - 5) Secure the cartridge to the headshell tentatively (not too firmly).
  - 6) Adjust the overhang. This is accomplished by moving the tonearm above the center spindle of the platter, sliding the cartridge inside the headshell back and forth and fixing it so that the distance between the stylus tip and the centre of the centre spindle is about 16 mm (5/8"), as shown.
  - 7) When the above adjustment is finished, re-adjust the horizontal balance of the tonearm, the tracking force, and Anti-Skate Control following the instructions given on pages 4 and 5. Be sure to adjust the tracking force to the value specified by the manufacturer of the new cartridge.
- Any cartridge weighing from 5 to 10 grams may be used with the BSR 150SX.
  - Some cartridges may produce hum. If this happens, it may be reduced by disconnecting the ground lead of the turntable from your stereo amplifier (read the operating manual of the cartridge for more detail).

## ACCESSORIES

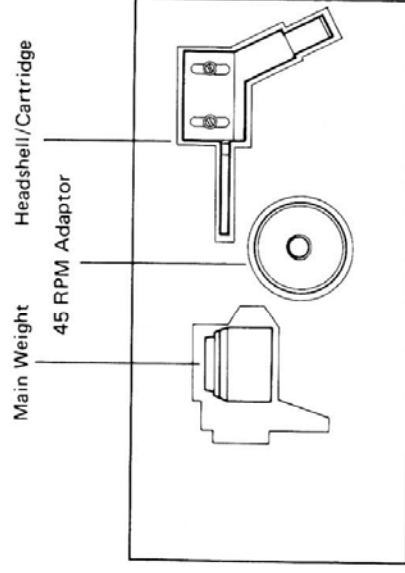

Fig. 2

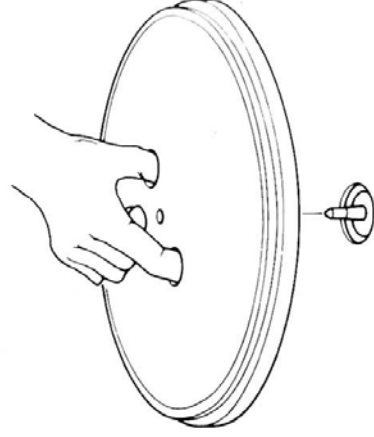

Fig. 3 Mounting the Platter

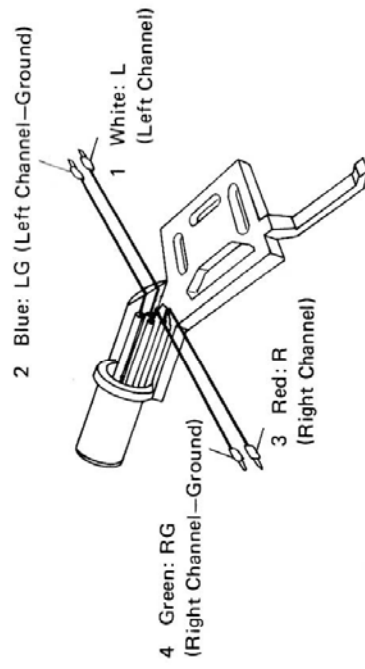

Fig. 4 Replacing Cartridge

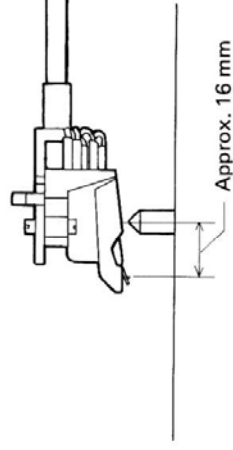

Fig. 5 Adjusting Overhang

## REPLACING THE STYLUS

To replace the stylus, first loosen the lock screw of the tonearm, and remove the headshell from the tonearm. Then the entire stylus holder may be pulled off the cartridge, as illustrated. To mount a new stylus, simply reverse the procedure, take care not to damage the stylus tip.

- The life of a diamond stylus is anywhere from 800 to 1,000 hours, but it is recommended to replace it earlier for best record playing results.
- The replacement stylus for the cartridge provided is designated the ADC RSQ34 MKIII, and may be purchased from your ADC or BSR dealer.

## RECOMMENDED CARE

- Before and after playing a record, clean the stylus tip and the record surface, gently with a soft brush.
- Do not place two or more records on the platter at the same time as it may cause slipping.
- During playback of your record, do not touch the platter or tonearm, and do not turn off the power switch or disconnect the power cord as these actions may damage your record and cause trouble.

## ADJUSTING THE TONEARM

### ADJUSTING HORIZONTAL BALANCE

- 1) Set the Anti-Skate Control to "0".
- 2) Ensure the Cueing Lever is down, toward yourself.
- 3) Pull the stylus cover off the cartridge.
- 4) Release the tonearm from the tonearm rest. The tonearm will swing up or down, or sideways, and so care must be taken to avoid damage to the stylus.
- 5) Install the Main Weight and turn it to move it forward or backward to balance the entire tonearm support. Leave the Main Weight where it balances the tonearm horizontally, as shown.
- 6) When the above adjustment is finished, replace the stylus cover and return the tonearm to the tonearm rest.
- 7) With the tonearm balanced horizontally, it has a tracking force of "0" grams. Turn only the Tracking Force Dial, holding the silver main weight, to set the dial to read "0" on the reference line of the tonearm shaft. Be sure *not* to turn the entire Main Weight yet, as it will spoil the horizontal balance of the tonearm.

### ADJUSTING TRACKING FORCE

Turn the Main Weight until the Tracking Force Dial indicates the appropriate tracking force for your cartridge. The standard cartridge provided operates best with a tracking force of 2.0 grams.

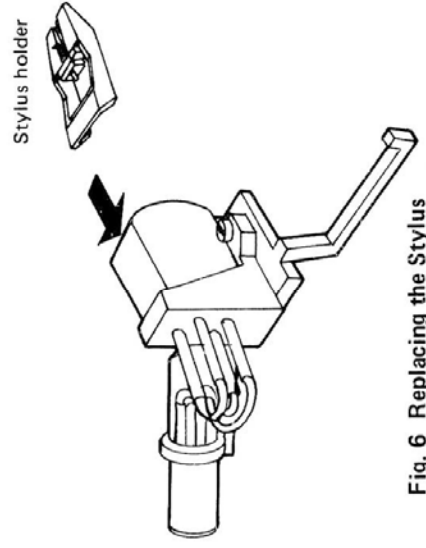

Fig. 6 Replacing the Stylus

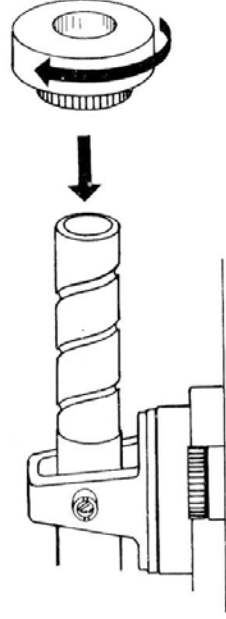

Fig. 7 Attaching the Main Weight

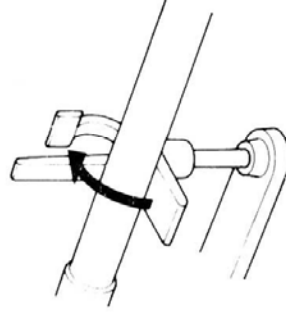
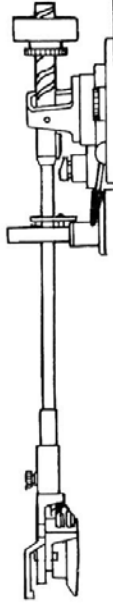
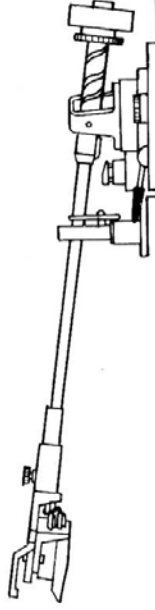

Fig.

1. Balanced



2. Unbalanced



2. Unbalanced



Fig. 8 Adjusting the Horizontal Balance

### ADJUSTING THE ANTI-SKATE CONTROL

As the cartridge tracks a revolving disc record, the stylus tends to be pulled toward the center of the disc. This "inside force" presses the stylus against the inner wall of the record groove, with the result that the stylus ability to track the groove faithfully is deteriorated and the reproduced sound is slightly distorted. The Anti-Skate Control (or, Inside Force Canceller) offsets this harmful force, and only needs to be set to the same gram indication as the tracking force applied above. In other words, if you are using the cartridge provided with the turntable, the Anti-Skate Control should be set so that the numeral "2.0" aligns with the reference line.

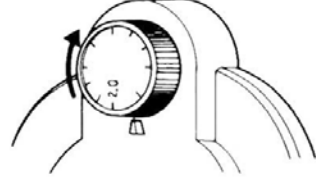

Fig. 9 Adjusting Anti-skate Control

### CONNECTING TO A STEREO AMPLIFIER

Connect the cords extending from the turntable to your stereo amplifier — the cord with a white plug to the LEFT PHONO terminal of your amplifier, and the cord with a red plug to the RIGHT PHONO terminal of your amplifier. Also connect the grounding lead of the turntable to the GND terminal of your amplifier. Finally, the power cable of the turntable should be connected to an appropriate AC outlet.

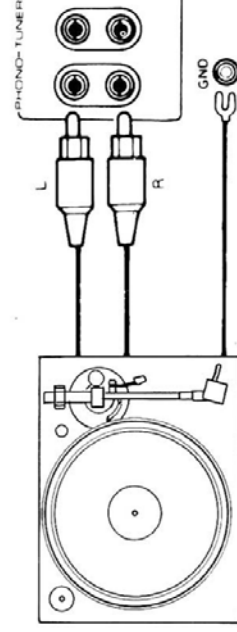

Fig. 10 Connecting to a Stereo Amplifier

### FRONT PANEL CONTROLS

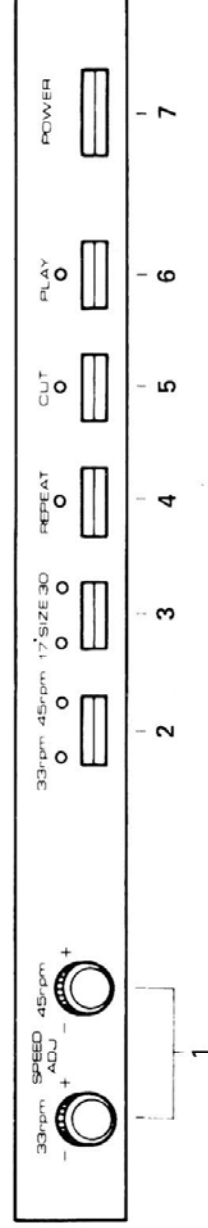

Fig. 11

#### 1. SPEED ADJ. (Pitch Control)

Turn these controls to adjust the pitch against the specified speed (stroboscope appears still).

Turn clockwise to increase the speed, and counterclockwise to reduce. Use the 33 rpm control for 33 rpm discs and the 45 rpm control for 45 rpm discs.

#### 2. SPEED SELECTOR BUTTON

Select the desired Speed with this button in accordance with the record to be played.

33 (not pressed/green indicator lights): For 33 rpm records.  
45 (pressed/red indicator lights): For 45 rpm records.

#### 3. DISC SIZE SELECTOR

Set the size in accordance with the disc to be played.  
(30)(not pressed: red indicator light): For 30 cm (12") discs.  
17 (pressed/green indicator lights): For 17 cm (7") discs.

#### 4. REPEAT button

Press (green indicator lights) for repeat play.

Press the CUT button to release the repeat play setting.

#### 5. CUT button

Press to stop playing. When this button is pressed (green indicator lights), the tonearm automatically returns to the tonearm rest and the platter stops its rotation. The REPEAT button is released at the same time if the repeat play is in progress.

#### 6. PLAY button

Press for AUTO play. When this button is pressed (green indicator lights), the platter starts its rotation and the tonearm automatically moves onto the record and play begins.

#### 7. POWER switch

Press to supply the power.

## OPERATING INSTRUCTIONS CUE/PAUSE OPERATION

The tonearm may be cued up by moving the cueing lever toward the rear of the unit and the stylus lowered to the record groove by returning the cueing lever to the forward position.

Viscous cueing gently lowers the stylus to the record groove, thereby providing maximum protection to both stylus and record. The cueing lever may also be used as a 'PAUSE' control to interrupt at any time.

### ADJUSTING SPEED (PITCH CONTROL)

Turn the power on. Cue the tonearm up and move it out of the arm rest. The platter will begin rotating. After selecting the speed with the Speed Selector Button, adjust the appropriate speed control (33 RPM control for 33 RPM and 45 RPM control for 45 RPM) until the strobe pattern appears stationary. If the pattern appears to be flowing to the left, turn the pitch control to the left to reduce the speed. If the pattern appears to be flowing to the right, turn the pitch control to the right to increase the speed.

**NOTE:** The turntable platter will not rotate while the tonearm is in the arm rest.

### MANUAL PLAY

Carry out the manual play in the following manner if you wish to start playing from the middle of a record or play non-standard record.

1. Set the volume on your amplifier to minimum. Turn the power switch on, set the FUNCTION switch to PHONO.
2. Turn the POWER switch of this unit ON.
3. Remove the stylus cover and release the tonearm lock clip.
4. Lift the cueing lever as shown in Fig. 13.
5. Gently place your finger on the hook of the headshell and move it to the beginning of the track you wish to play.
6. Set speed selector button and disc size selector to the appropriate positions and fine adjust the speed.
7. Pull the cueing lever down toward yourself. The tonearm will lower gently onto the record and begin playing.
8. Adjust the volume on the amplifier.
9. The tonearm will automatically return to the armrest when the record finishes and the platter stops rotating. To stop play before the record finishes, press the CUT button.

### AUTO PLAY

1. Set the volume of your amplifier to minimum and turn the Power switch on. Set the Function switch to PHONO.
2. TURN the Power switch of this unit on. (pressed)
3. Remove the stylus cover and release the armrest lock clip. Pull the cueing lever down toward yourself.
4. Select the appropriate speed for the record. Press the button for 45 rpm record (red indicator lights) or do not press for 33 rpm (green indicator lights).
5. Fine adjust the speed with the appropriate speed adjust control if necessary, as above.
6. Select the disc size for the record you are going to play. Press the button for 17 cm (7") disc (green indicator lights) or do not press for 30 cm (12") disc (red indicator lights).
7. Press the PLAY button (green indicator lights). The platter starts to rotate and the tonearm automatically moves to the lead-in groove of the record and lowers itself to start playing.

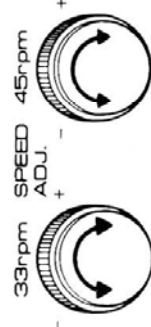

Fig. 12

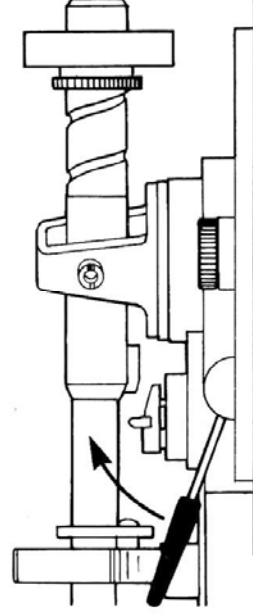

Fig. 13 Cueing lever

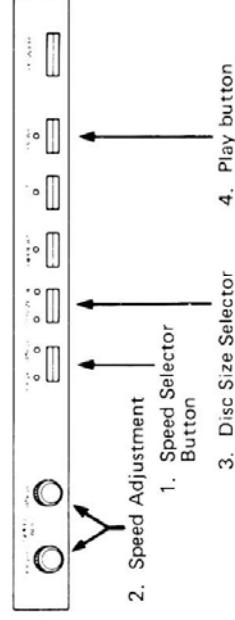

Fig. 14 Operating sequence on the front panel.

8. Adjust the volume on your amplifier.
9. The tonearm automatically returns to the armrest when the playing finishes and the platter stops its rotation (Auto return).
10. Attach the stylus cover for protection, and lock the tone arm with the lock clip.
  - For AUTO play, make sure to pull the cueing lever down toward yourself.
  - The Disc Size Selector is not effective during Automatic operation of the tonearm.

### AUTO CUT

If you want to stop playing before the record finishes, follow the steps below.

1. Press the CUT button during playing.
2. The tonearm automatically returns to the tonearm rest and the platter stops its rotation to stop playing.

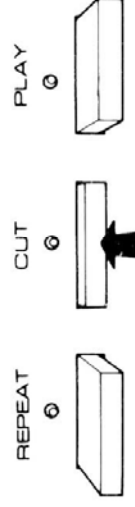

Fig. 15 CUT button – ON.

### REPEAT PLAY

This function will repeat playing the same record continuously.

1. Operate the steps (1) ~ (6) given in the AUTO PLAY instructions.
2. Press the REPEAT button (green indicator lights).
3. Press the PLAY button. The platter starts to rotate and the tonearm automatically moves and lowers itself onto the lead in groove of the record to start playing.
4. When the record finishes: the tonearm automatically returns to the tonearm rest once, then moves onto the lead in groove of the record to start playing again.
5. To cancel REPEAT play, press the CUT button (green indicator lights). This releases the REPEAT button and the tonearm returns to the tonearm rest and the platter stops its rotation.

Press the CUT button at the end of a track, if you press it in the middle of a track, the playing stops there.

- REPEAT play can also be actuated by pressing the REPEAT button after commencing the auto play.

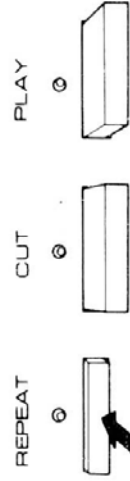

Fig. 16

### TABLE OF TROUBLESHOOTING INSTRUCTIONS

SYMPTON	CAUSE	REMEDY
Platter does not revolve.	<ul style="list-style-type: none"> <li>• Power cable is unplugged.</li> </ul>	<ul style="list-style-type: none"> <li>• Insert power cable firmly into AC outlet.</li> </ul>
No sound.	<ul style="list-style-type: none"> <li>• Connection cords are unplugged from stereo amplifier.</li> </ul>	<ul style="list-style-type: none"> <li>• Connect cords firmly.</li> </ul>
	<ul style="list-style-type: none"> <li>• Headshell is not connected properly.</li> </ul>	<ul style="list-style-type: none"> <li>• Tighten lock nut.</li> </ul>
	<ul style="list-style-type: none"> <li>• FUNCTION switch of stereo amplifier is set to wrong position.</li> </ul>	<ul style="list-style-type: none"> <li>• Set FUNCTION switch to PHONO.</li> </ul>
	<ul style="list-style-type: none"> <li>• TAPE MONITOR switch of stereo amplifier is set to TAPE (or MONITOR).</li> </ul>	<ul style="list-style-type: none"> <li>• Set TAPE MONITOR switch to SOURCE.</li> </ul>
	<ul style="list-style-type: none"> <li>• Lead wires of cartridge are disconnected.</li> </ul>	<ul style="list-style-type: none"> <li>• Connect lead wires firmly to terminal pins of headshell.</li> </ul>
Tempo of reproduced music is strange.	<ul style="list-style-type: none"> <li>• Speed Selector is in wrong position.</li> </ul>	<ul style="list-style-type: none"> <li>• Reset Speed Selector to correct speed for record.</li> </ul>
Sound is noisy.	<ul style="list-style-type: none"> <li>• Dust or dirt on record surface.</li> </ul>	<ul style="list-style-type: none"> <li>• Clean record surface.</li> </ul>
	<ul style="list-style-type: none"> <li>• Dust or dirt on stylus.</li> </ul>	<ul style="list-style-type: none"> <li>• Clean stylus.</li> </ul>
	<ul style="list-style-type: none"> <li>• Tracking force is too light.</li> </ul>	<ul style="list-style-type: none"> <li>• Adjust for proper tracking force.</li> </ul>
	<ul style="list-style-type: none"> <li>• Stylus is worn.</li> </ul>	<ul style="list-style-type: none"> <li>• Replace stylus.</li> </ul>
Sound is noisy.	<ul style="list-style-type: none"> <li>• Grounding lead is not connected to amplifier.</li> </ul>	<ul style="list-style-type: none"> <li>• Connect grounding lead to amplifier.</li> </ul>



Sound is distorted.	● Stylus is worn.	● Replace stylus.
	● Dust or dirt on stylus.	● Clean stylus.
	● Tracking force is too light.	● Adjust for proper tracking force.
	● Overhang adjustment is wrong.	● Re-adjust overhang.
Loud howling noise.	● Acoustic feedback.	● Move turntable away from speaker systems.
	● Turntable is not placed on horizontal plane.	● Place turntable on horizontal plane.
Stylus moves irregularly.	● Tracking force is too light, and Anti Skate Control is not adjusted properly.	● Re-adjust tracking force and Anti-Skate Control.
	● Tonearm lock clip engaged.	● Release the tonearm locking clip.
Auto-play does not work.	● Cueing Lever is not down.	● Pull Cueing Lever down.
Auto-return and autocut do not work, and tonearm does not descend at Auto-Play.	● Disc Size Selector is in wrong position.	● Reset Disc Size Selector to correct size of record.

In any case, if none of the above does the job and you still have a problem — help is as close as your local BSR Authorized Repair Center. Refer to your warranty card for a toll free number you may call 24 hours a day, seven days a week for your nearest Authorized Service Agency. Bring your unit in and be ready to describe the symptoms — we will get you back into good stereo sound ASAP!



ROUTE 303, BLAUVELT, NEW YORK 10913 AREA CODE 914 358-6060 — TELEX 137441

PRINTED IN JAPAN